

**PLEASE!! READ THESE INSTRUCTIONS!
EACH SEPARATE CONTROL YOU BOUGHT
HAS ITS OWN INSTRUCTIONS BUT
WE RECOMMEND YOU USE THESE FIRST.**

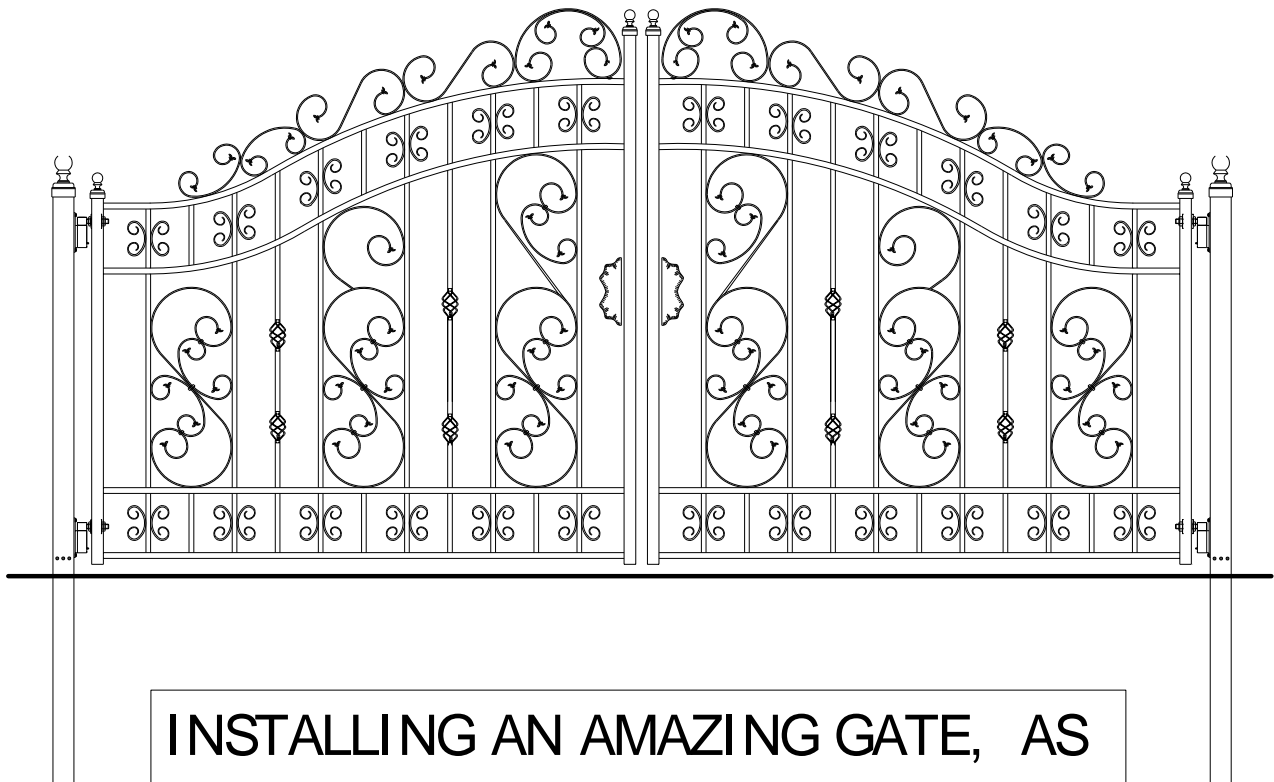

**INSTALLING AN AMAZING GATE, AS
USED WITH A SLIDER FRAME**

**FROM THE ORIGINATORS OF THE
PRE-HUNG AUTOMATIC GATE SYSTEM**

**AMAZING GATES OF AMERICA L.L.C.
608 TIERRA MONTANA LOOP
BERNALILLO, NEW MEXICO 87004
505-771-8777
WWW.AMAZINGGATES.COM**

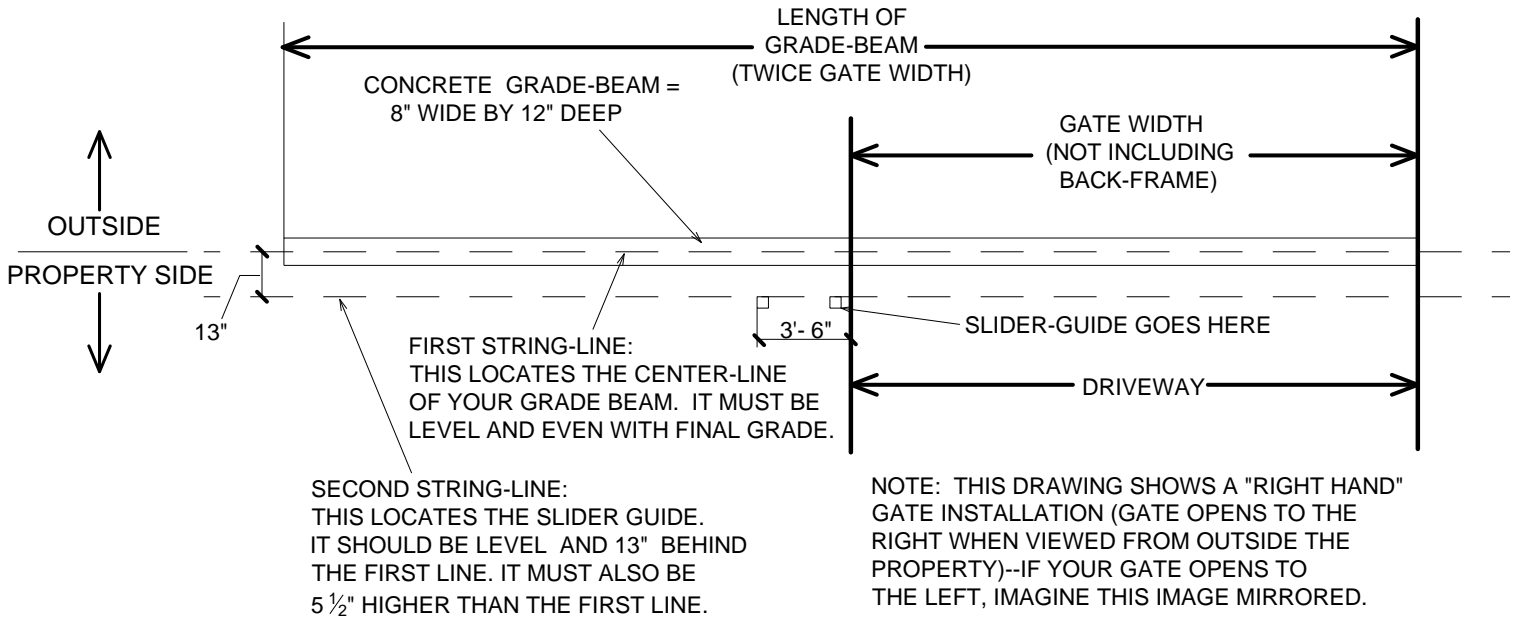

LAYING OUT YOUR GATE

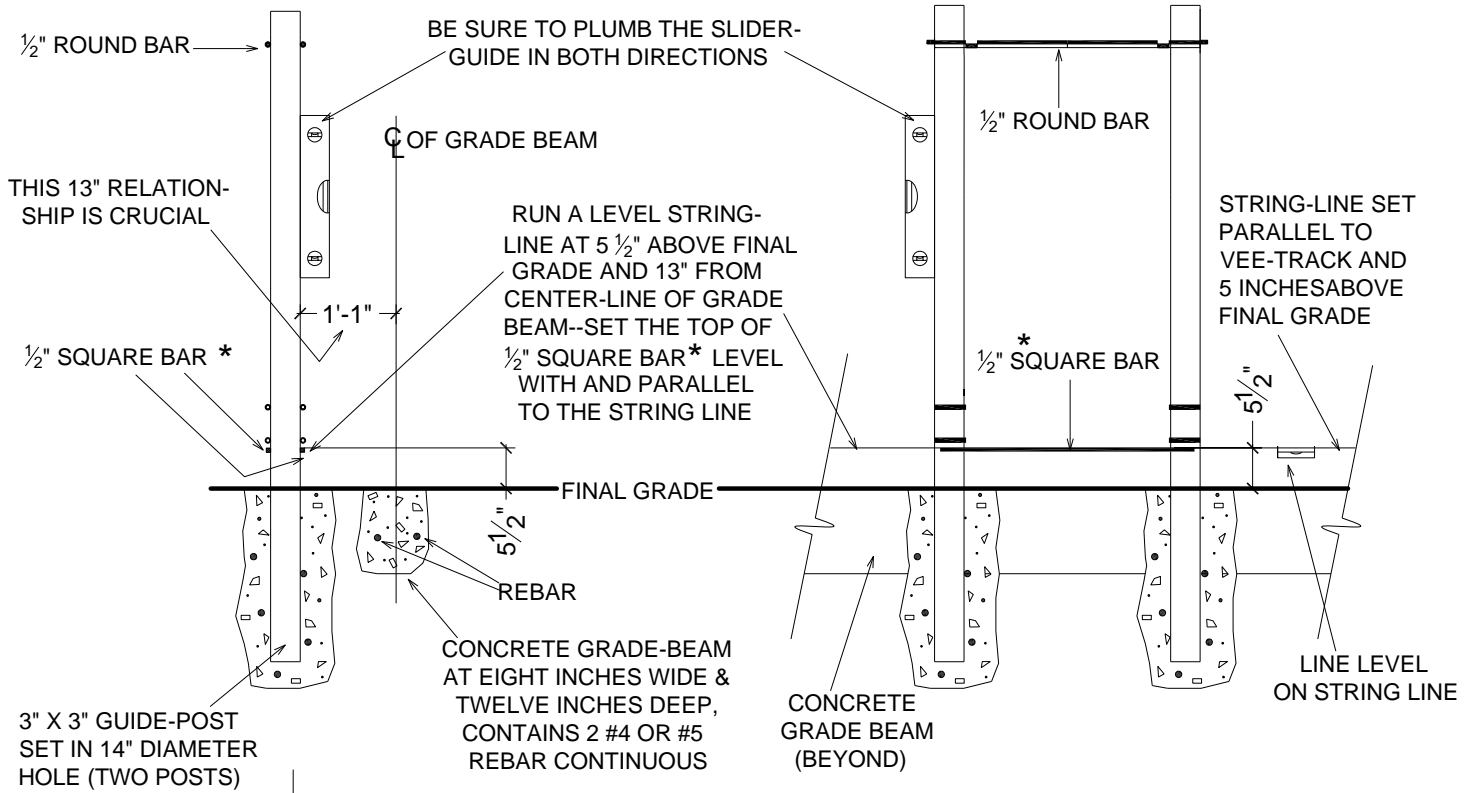

INSIDE
 OUTSIDE
END VIEW

PROPERTY-SIDE VIEW

SLIDER-GUIDE INSTALLATION

1

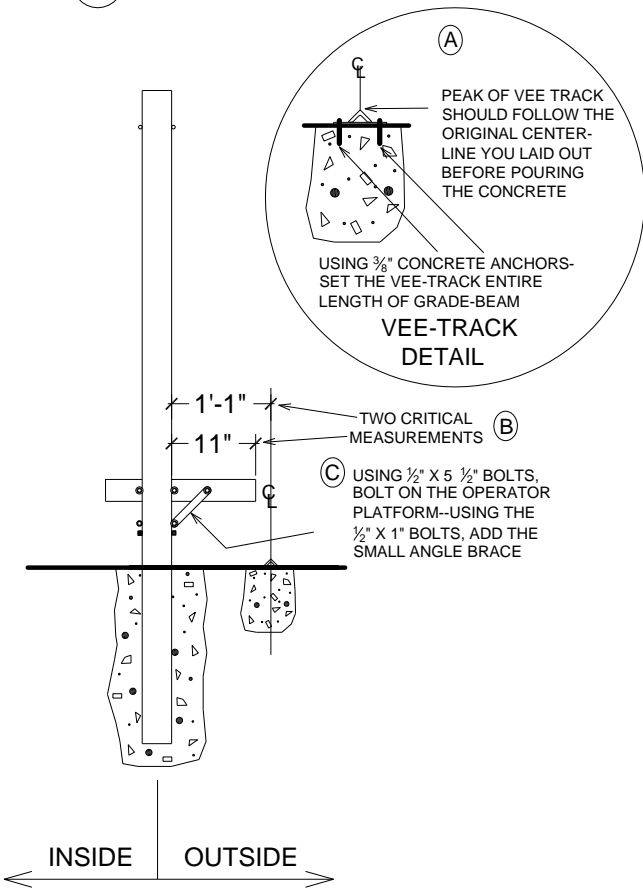

2

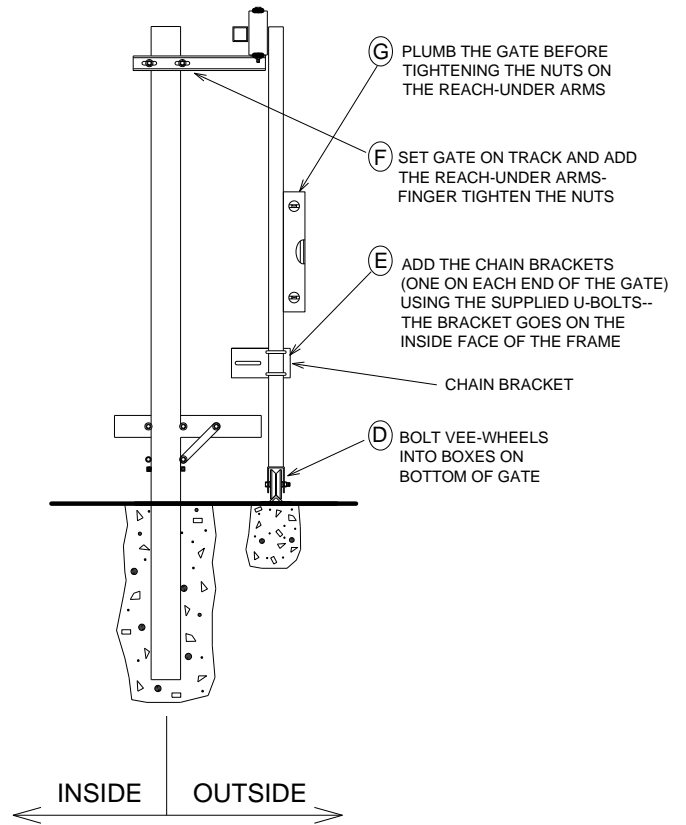

3

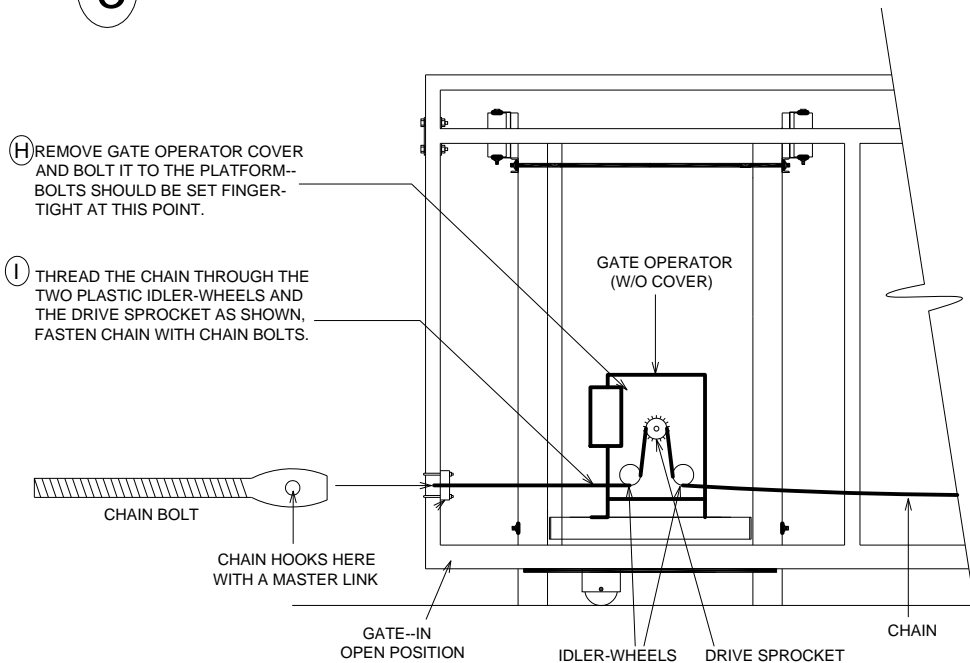

VIEW FROM OUTSIDE

NOTES:

1. MAKE SURE THE CENTER SLOT ON THE CHAIN BRACKET IS LEVEL WITH THE BOTTOM OF THE IDLER-WHEEL.
2. THE CHAIN SHOULD NOT BE OVER TIGHTENED-- THERE SHOULD BE ABOUT A 2" TO 2 1/2" DROOP IN THE CHAIN WHEN THE GATE IS IN THE CLOSED POSITION.
3. BEFORE YOU FINALLY TIGHTEN THE OPERATOR MOUNTING BOLTS TO THE PLATFORM, BE SURE THE CHAIN AND THE GATE OPERATOR ARE PARALLEL TO THE GATE. THERE ARE SLOTS IN THE PLATFORM THAT ALLOW THIS ADJUSTMENT.
4. THE FINAL STEPS OF HOOKING UP THE WIRING AND SETTING THE LIMIT SWITCHES WILL BE FOUND IN THE MANUFACTURERS MANUAL THAT COMES WITH THE GATE OPERATOR.

SLIDER-GUIDE INSTALLATION

FOR SLIDER FRAME STYLE

WE RECOMMEND FASTENING THE GATES TO THE SLIDER FRAME AFTER THE SLIDER FRAME IS MOUNTED ON THE VEE-TRACK AND MOVING FREELY IN THE SLIDER GUIDE

FASTENING GATES TO SLIDER FRAME

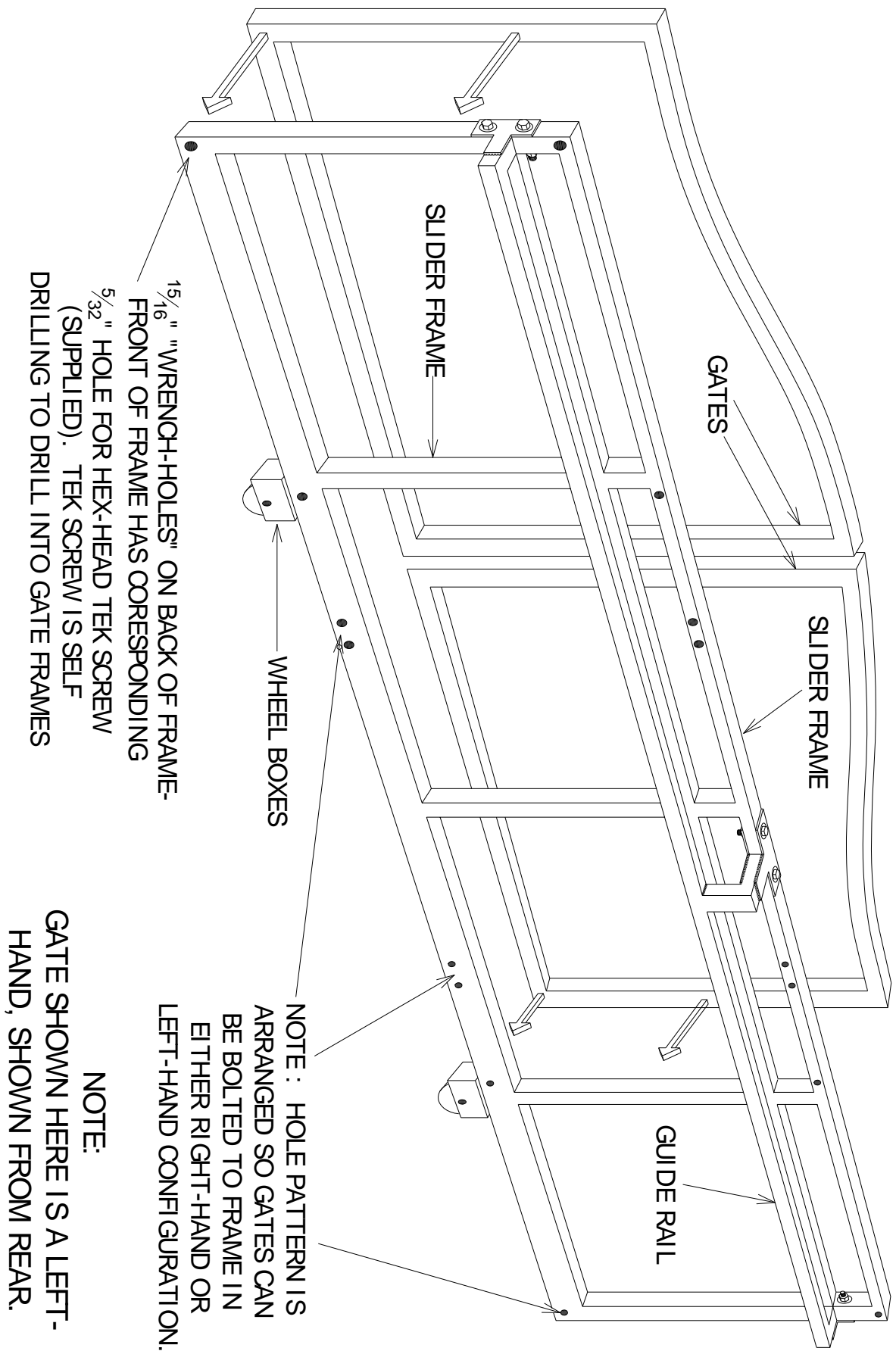

15/16" "WRENCH-HOLES" ON BACK OF FRAME-FRONT OF FRAME HAS CORRESPONDING 5/32" HOLE FOR HEX-HEAD TEK SCREW (SUPPLIED). TEK SCREW IS SELF-DRILLING TO DRILL INTO GATE FRAMES

NOTE: HOLE PATTERN IS ARRANGED SO GATES CAN BE BOLTED TO FRAME IN EITHER RIGHT-HAND OR LEFT-HAND CONFIGURATION.

NOTE: GATE SHOWN HERE IS A LEFT-HAND, SHOWN FROM REAR.

NOTE: SLIDER GUIDE, VEE TRACK, GATE PICKETS AND MESH ARE NOT SHOWN FOR SAKE OF CLARITY