

**PLEASE!! READ THESE INSTRUCTIONS!
EACH SEPARATE CONTROL YOU BOUGHT
HAS ITS OWN INSTRUCTIONS BUT
WE RECOMMEND YOU USE THESE FIRST.**



**INSTALLING AN AMAZING GATE
WITH A VIKING F-1 OPERATOR**

**FROM THE ORIGINATORS OF THE
PRE-HUNG AUTOMATIC GATE SYSTEM**

**AMAZING GATES OF AMERICA L.L.C.
608 TIERRA MONTANA LOOP
BERNALILLO, NEW MEXICO 87004
505-771-8777
WWW.AMAZINGGATES.COM**

LAYING OUT YOUR AMAZING GATE

Determine the gate location and lay it out on the ground. White spray paint or white flour work well and some stakes and a string line are helpful. Basic principals include: THE POCKET, ie. the gate's distance from the turn into your driveway, SQUARENESS, ie. the gate's angle to the drive path, INSWING/OUTSWING, and HANDING, ie. which side of the gate has the hinges?

Below are drawings showing some layout scenarios. Sometimes space limitations may force you to use a less desirable layout.

THE POCKET

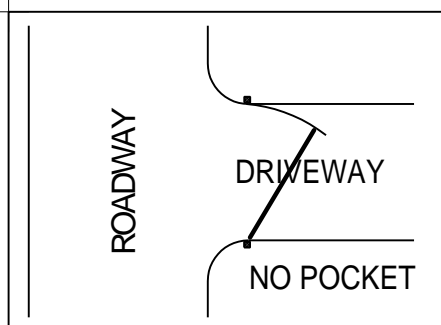

WORST CASE- PREVENTS YOU FROM PULLING OFF ROAD AS YOU WAIT FOR THE GATE. PREVENTS LARGER VEHICLES FROM MAKING THE TURN IN

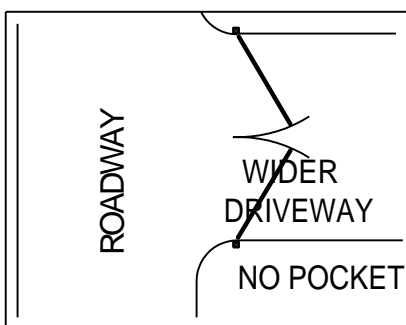

IMPROVED CASE- DOESN'T ALLOW A POCKET BUT ALLOWS LARGER VEHICLES (A MOVING VAN ETC.) TO MAKE THE TURN INTO THE DRIVEWAY

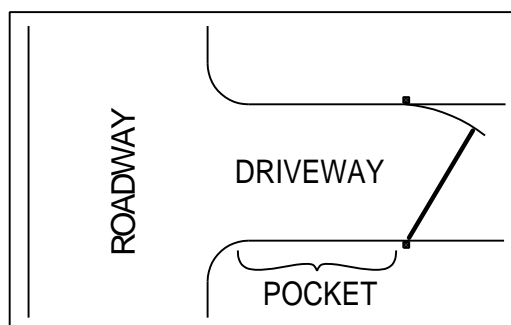

BEST CASE- LETS YOU COMPLETE THE TURN AND PULL OFF ROAD WHILE YOU WAIT FOR GATE TO OPEN

1. It is most desirable to have a slight "pocket" in front of your gate. If the gate must be right up against your road, a wider opening should be considered.

SQUARENESS

1. Since most automatic gates open only slightly more than ninety degrees, it is important to make the gate perpendicular to your drive path.

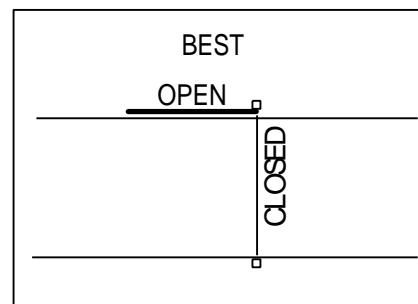
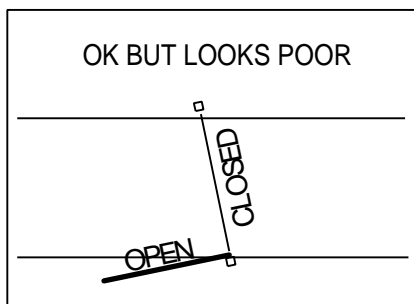
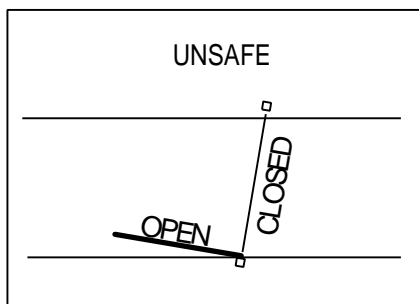

1. Curved driveways demand extra care in layout. No one wants their gate hit by a vehicle.

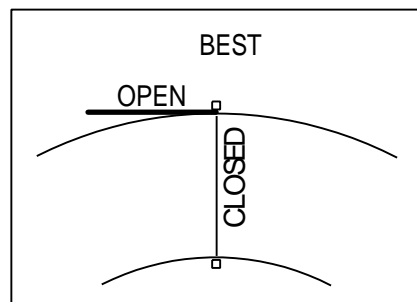
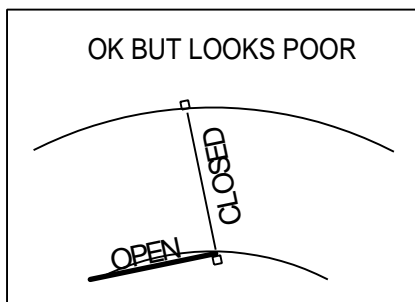
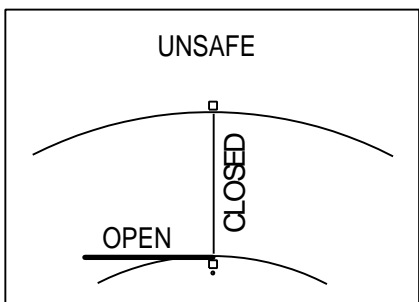

LAYING OUT YOUR AMAZING GATE

INSWING/OUTSWING

1. The most desirable configuration for a swinging gate is to swing inward. However, certain driveway conditions can make it necessary to swing a gate outward.

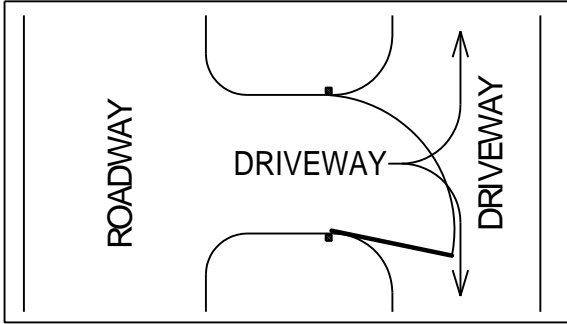

PROBLEM (AT LEFT)
WHEN OPEN, IN-SWINGING GATE PROTRUDES INTO DRIVE SPACE

SOLUTION (RIGHT)
CHANGE GATE TO AN OUT-SWING

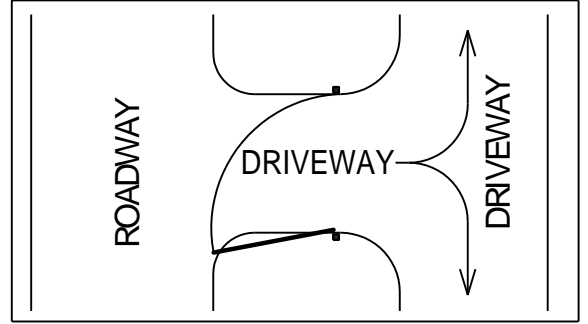

2. Another condition that may force you to swing your gate outward is an upward sloping driveway.

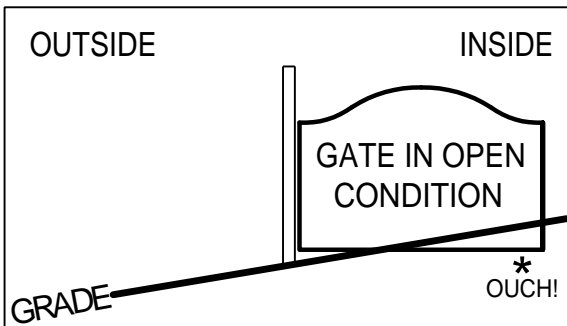

PROBLEM (AT LEFT)
WHEN IN-SWINGING GATE OPENS, IT HITS GROUND. YOU CAN HANG GATE HIGHER ON THE POST BUT MORE THAN 6"-8" ABOVE GRADE LOOKS BAD. **SOLUTION (RIGHT)**
GATE INSTALLED AS AN OUT-SWING, PLENTY OF GROUND CLEARANCE

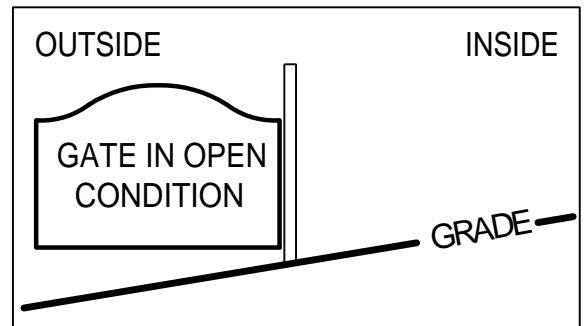

3. A linear operator (GTO, Patriot or Miracle I) can be set up as "pull-to-open" (drawing A below) or as "push-to-open" (drawing B below) ie. gate swings outward and the operator stays inside.

4. An articulated-arm operator (Elite CSW 200 or DoorKing 6100) can be set up to open inward (drawing C below) or to open outward (drawing D below) but the operator must go outside the gate.

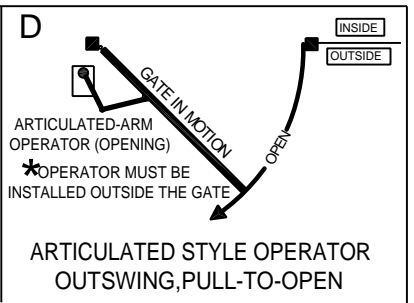
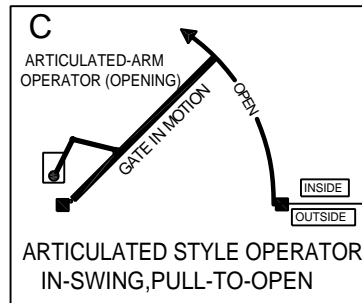
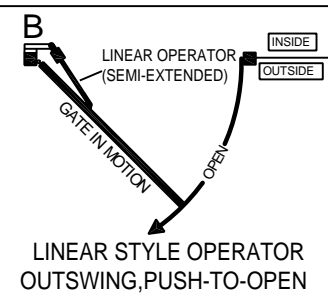
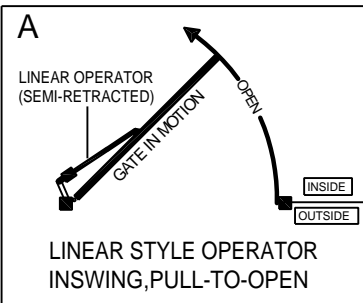

GTO's PATRIOTS AND ELITE MIRACLES

ELITE CSW AND DOOR KING 6100

"HANDING" YOUR GATE

Imagine standing OUTSIDE your gate, then ask yourself "are the hinges on the right or the left?" See the four examples below.

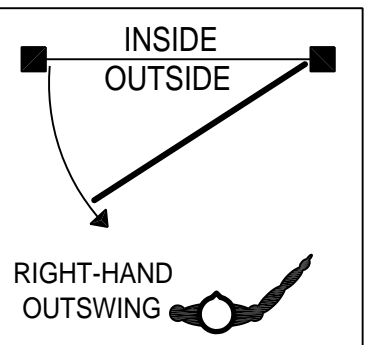
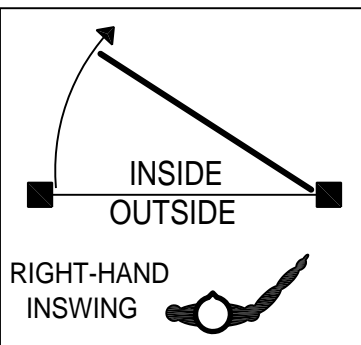
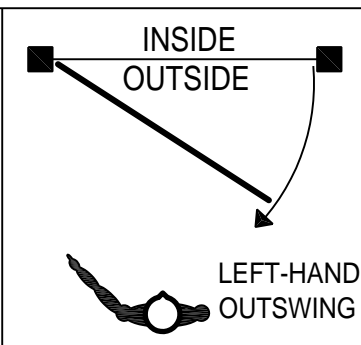
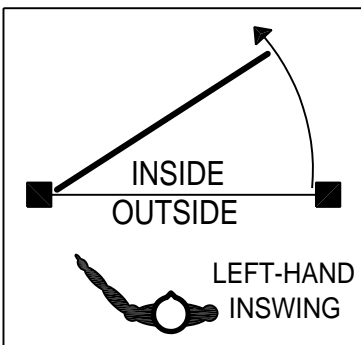

DRIVE GATES

SETTING THE POSTS

1 YOU WILL NEED:

1. STRING LINE AND LINE LEVEL.
2. SHOVEL/ POST HOLE DIGGERS/ DIGGING BAR
3. TAPE MEASURE AND A LEVEL
4. HAMMER AND STAKES
5. WHEELBARROW
6. PRE-MIXED CONCRETE (APPROX. 8-10 60 LB. OR 6-8 80 LB. SACKS)

2

USE A LINE-LEVEL ON THE STRING. SET THE STRING WHERE YOU WANT THE BOTTOM OF THE GATE WHEN IT IS CLOSED.

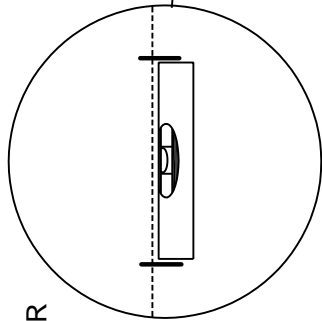

3

ALIGN THE ROW OF DIMPLES ON THE POST WITH THE LEVEL STRING

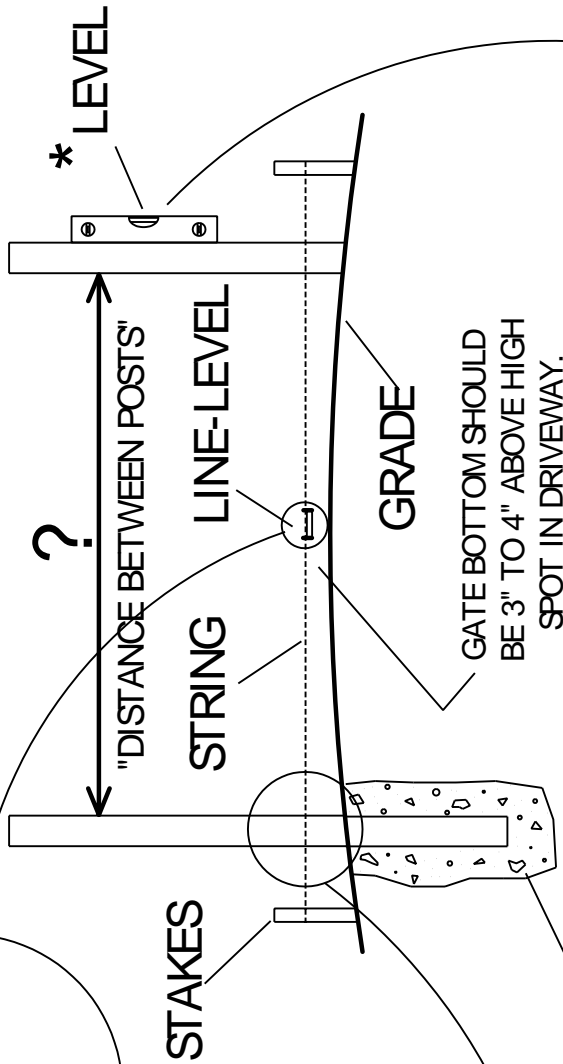
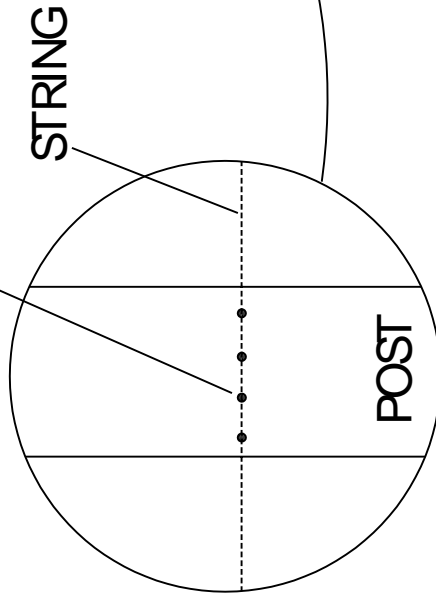

"DISTANCE BETWEEN POSTS" IS THE NOMINAL WIDTH OF YOUR GATE, I.E. IF YOU BOUGHT A 16 FOOT GATE, SET THE POSTS EXACTLY 16 FEET APART, 12 FOOT GATE, 12 FEET APART ETC.

4

SET THE POSTS IN CONCRETE, HOLE DIAMETER SHOULD BE AT APPROX. 16". DO NOT MAKE HOLE PERFECTLY ROUND. MIX CONCRETE STIFF SO THE POST WILL STAND UNAIDED UNTIL CONCRETE SETS (24 HOURS).

5

USE THE LEVEL TO PLUMB THE POSTS IN BOTH DIRECTIONS

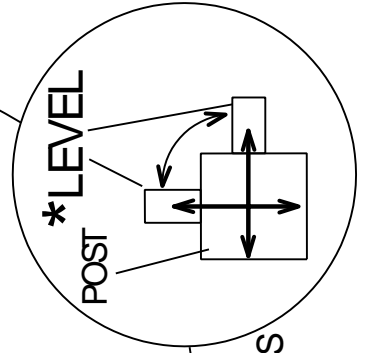

HANGING THE GATE

We will illustrate a single swing gate. A dual or bi-parting simply has a second hinge post in lieu of a strike post

BESIDES THE EQUIPMENT WE SHIPPED TO YOU, YOU WILL NEED: 1. 2 crescent wrenches
2. screwdrivers 3. a level 4. Some all-weather grease 5. A helper

1 PREP HINGES

Using the supplied machine screws bolt the hinge barrel assemblies to the posts. The other half of each hinge, the hinge-pin, bolts through the $\frac{3}{4}$ " holes in the gate itself. Each hinge-barrel takes a ball bearing and a hinge-pin. Using an all-weather grease, put a dollop on each ball bearing and insert a bearing into each barrel.

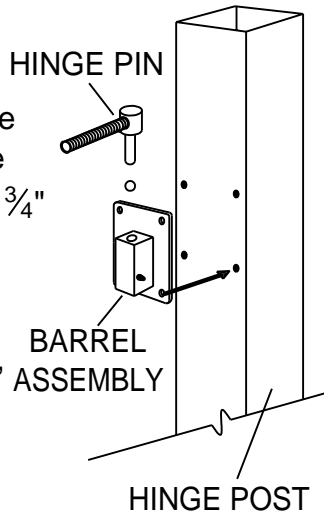

2 PREP HINGE-PINS

Next, put the threaded portion of the hinge-pins through the holes in the gate frame, tighten lightly with a wrench, making sure the unthreaded portion points down and is parallel to the gate frame.

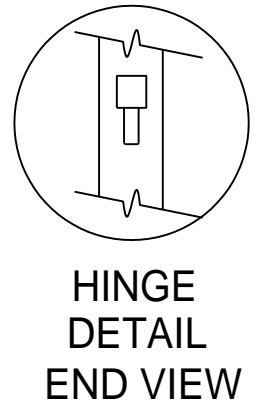
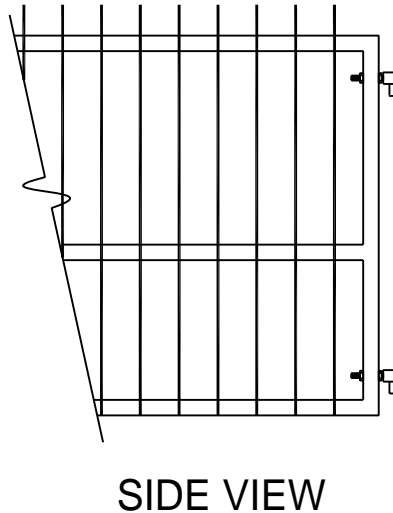

3 HANG THE GATE

Using a helper, lift the gate and gently slide it toward and down onto the hinge barrels. This may take two or three attempts since both hinge-pins must enter the barrels simultaneously.

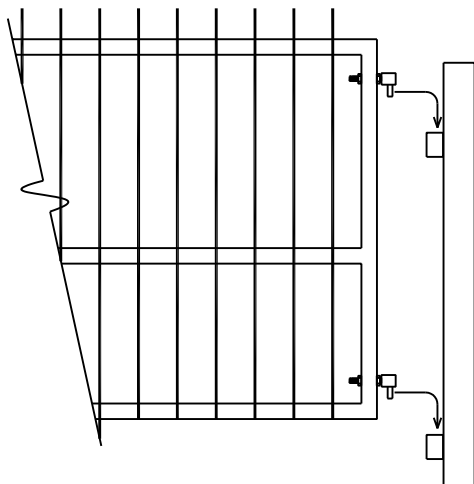

4 LEVEL AND TIGHTEN

Finally, using your level and the crescent wrenches, adjust the top and bottom hinge-pins with the nuts until the gate hangs exactly level. Check the swing, it should be smooth and quiet. Tighten the hinge-nuts completely.

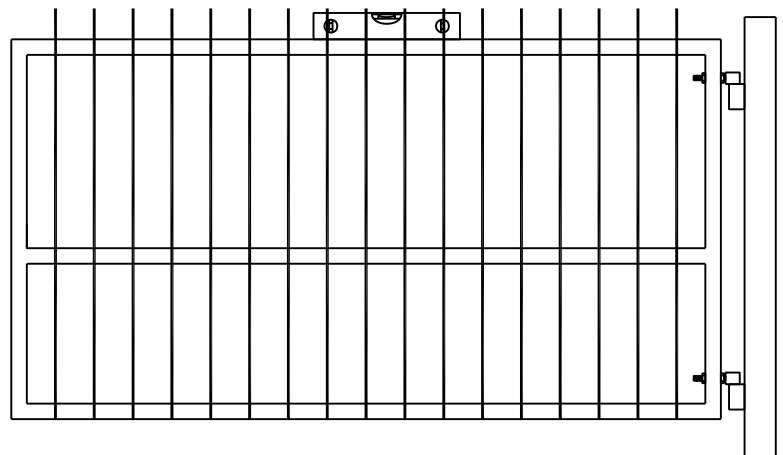

INSTALLING THE VIKING F-1- MASTER/SLAVE

FOR DUAL GATES

YOU WILL NEED:

1. TWO CONCRETE PADS, SHOULD GO AT LEAST 24 " DEEP INTO EARTH.
2. $\frac{3}{4}$ " PVC CONDUIT WITH THREE 90 DEGREE SWEEPS

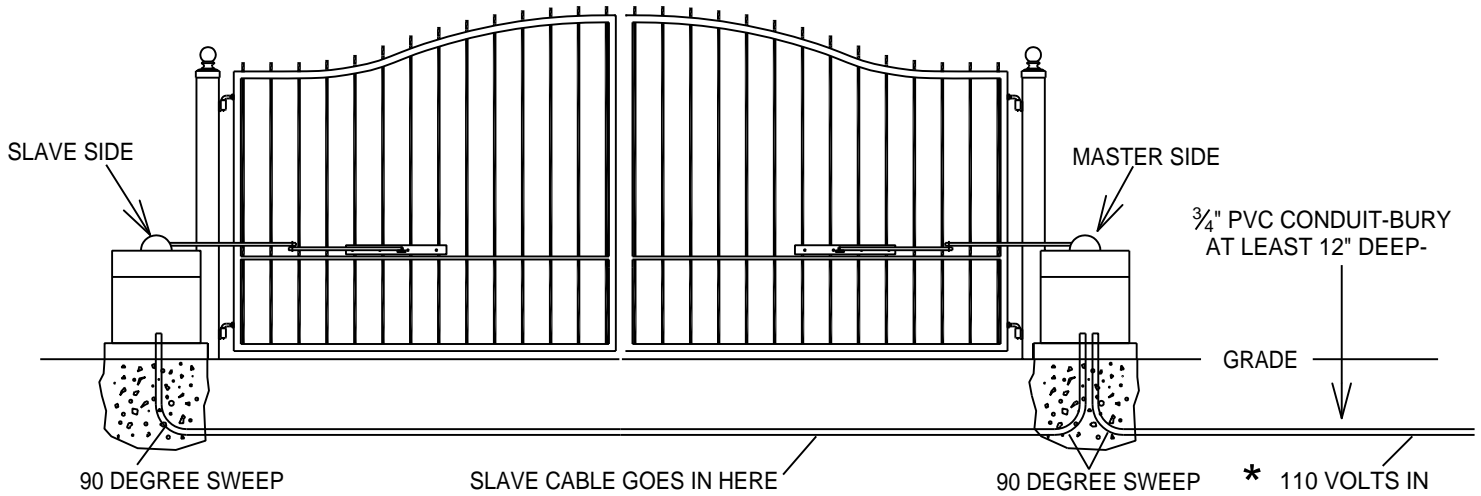

AT THIS POINT WE RECOMMEND THAT YOU USE THE MANUAL SUPPLIED BY VIKING STARTING ON PAGES 10 AND 11 SHOW HOW TO LOCATE THE OPERATOR AND PAGE 14 SHOW HOW TO SET THE LIMITS. WIRING INSTRUCTIONS START ON PAGE 17. THIS MANUAL THOROUGHLY EXPLAINS POWERING UP THE SYSTEM, SETTING THE LIMITS AND CONNECTING ALL STYLES OF CONTROLS.